

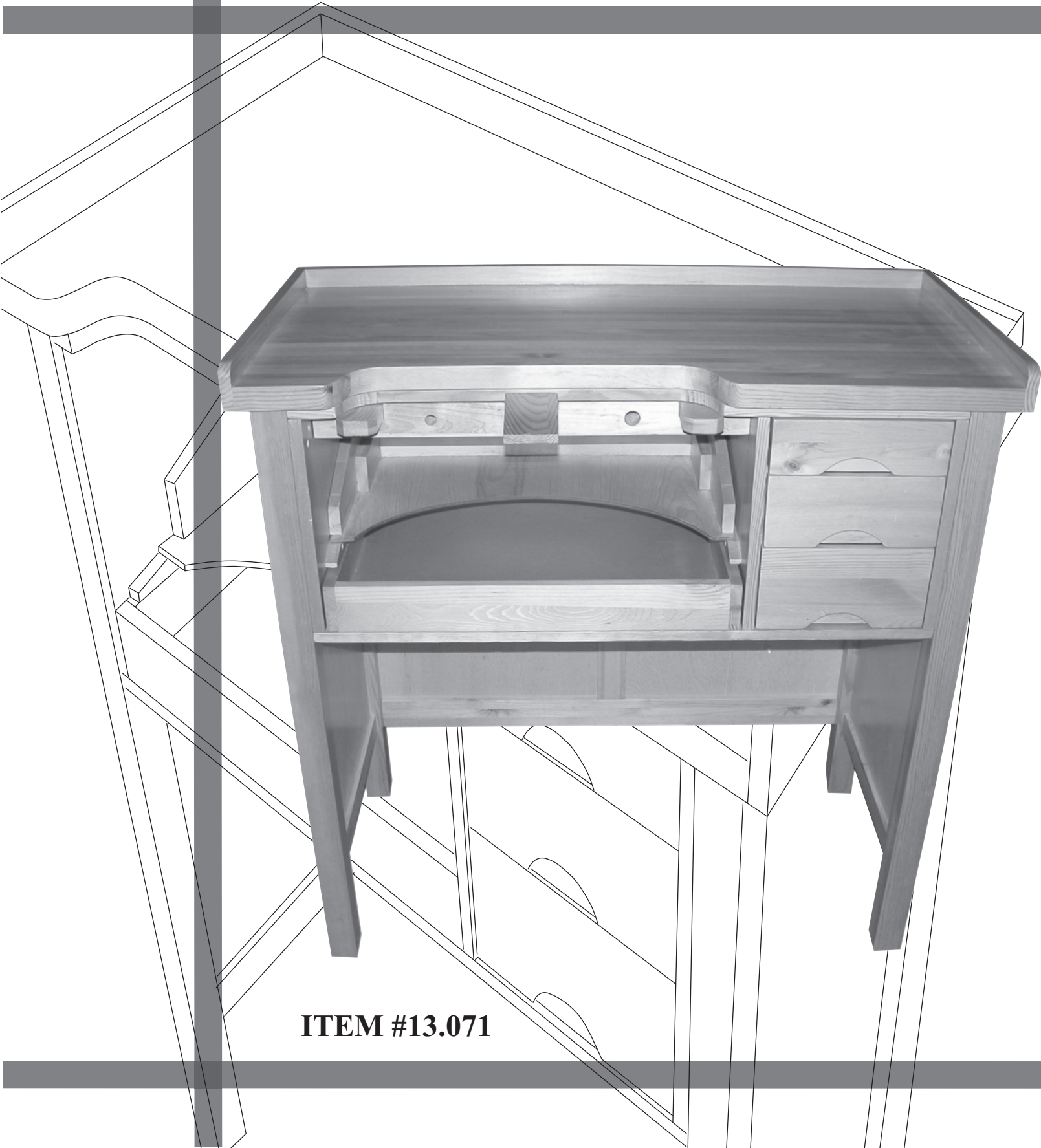

# NEW JEWELRY WORK BENCH



**ITEM #13.071**

# PARTS IDENTIFICATION

RIGHT SIDE - 1

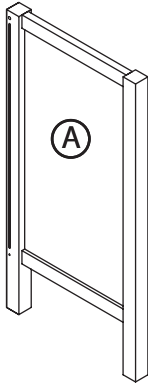

LEFT SIDE - 1

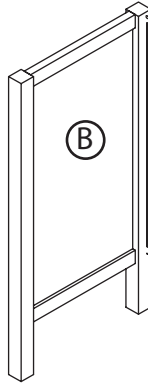

UPPER AND LOWER CROSSBARS (IDENTICAL) - 2

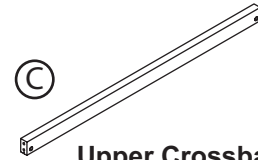

Upper Crossbar Measures 2-1/4" x 7/8" x 33"

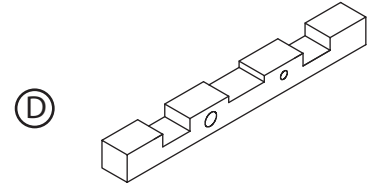

Bench Pin Holder - 1

REAR PANEL SUPPORT BAR - 1

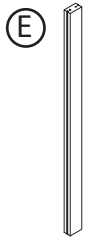

Measures 1-9/16" x 7/8" x 26-3/4"

BACK PANELS (IDENTICAL) - 2

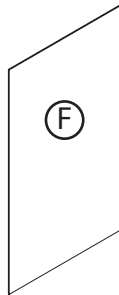

BENCH TOP - 1

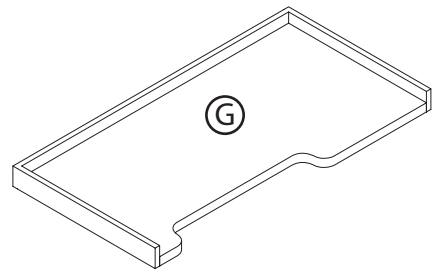

Bench Body

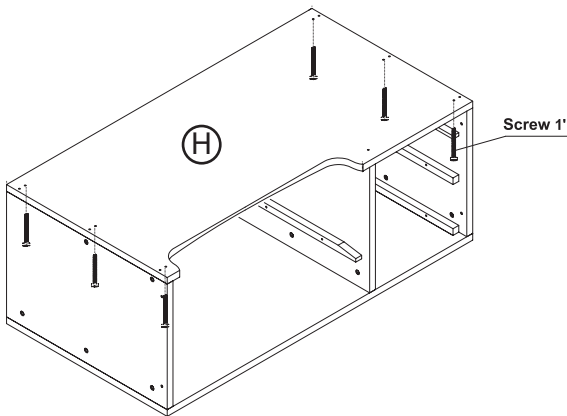

## Assembly Tools Required

Allen Wrench - supplied  
1/4" Flat Head Screwdriver  
Phillips Head Screwdriver

## Hardware - Shipped in top drawer

Six - 2-1/2" bolts with cams

Fifteen - 1" screws

Eight - 1-1/2" wood screws

Six - wood dowels

Six - Caps

Allen Wrench

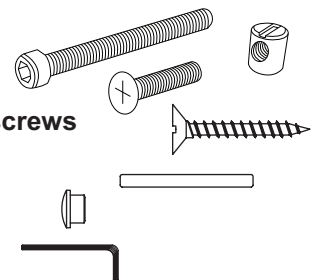

### Note:

Each bench was test assembled at the factory. Humidity and temperature affect wood. Use the Phillips head screwdriver to help align all of the screw holes. Stick the screwdriver into the screw hole and locate the second hole. Wiggle the screwdriver until the holes are perfectly aligned. This will make assembly much easier.

# 1

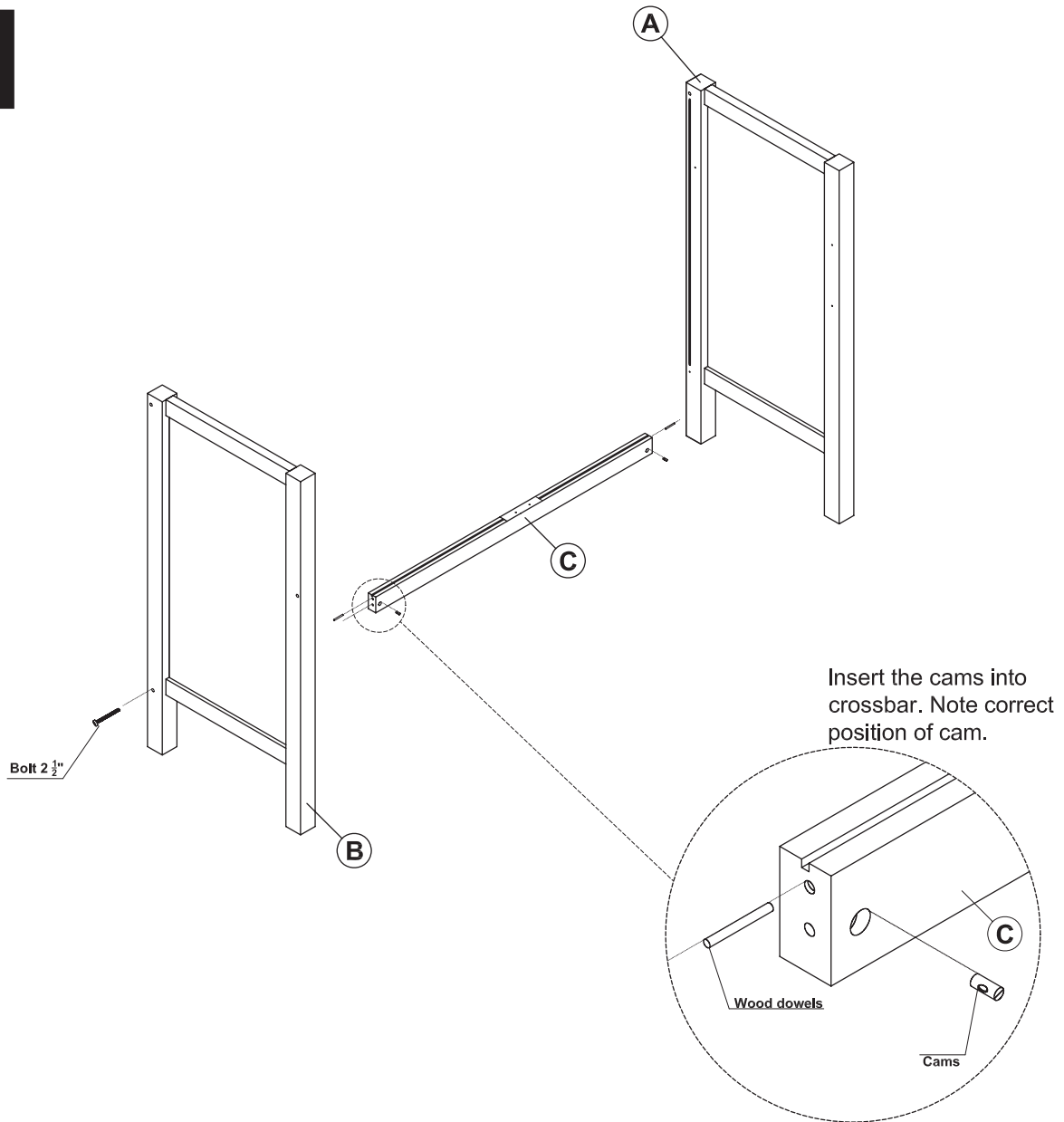

## **PARTS IDENTIFICATION**

- A Right Side - (1)
- B Left Side - (1)
- C Upper and Lower Crossbars - (*identical*)

## **STAGE 1- Bench Body Asembling**

### **Step 1**

**Attach lower cross bar (C) to sides A and B.**

**1. Insert two cams into crossbar. Note correct position of cam as shown in illustration.**

**2. Insert wood dowels into top hole of crossbar. See illustration.**

**3. Fasten both sides to lower cross bar using 2 1/2" bolts. Bolts screw into cams. If alignment is not correct, adjust using screwdriver to rotate the cam. Do not fully tighten.**

# 2

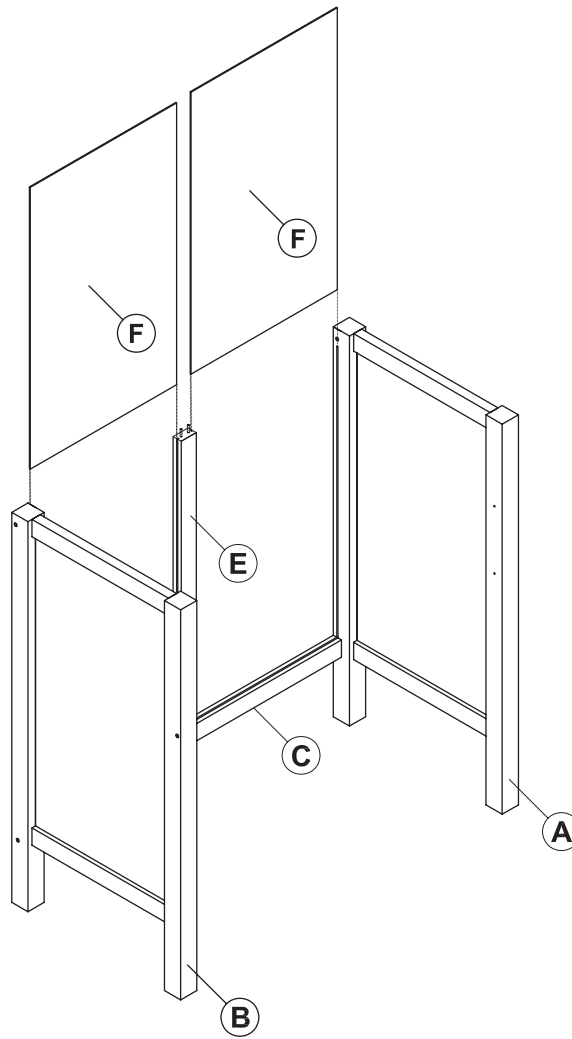

## **PARTS IDENTIFICATION**

- A Right Side - (1)
- B Left Side - (1)
- C Upper and Lower Crossbars - (*identical*)
- D Rear panel support bar - (1)
- E Back panels - (2 *pieces, identical*)

## **STAGE 1- Bench Body** **Asembling** **Step 2**

1. Insert two wood dowels into one side of the Rear Panel Support Bar (E).
2. Attach to the lower crossbar.
3. Insert back panel (F) into rooves on right side (A), lower crossbar (C), and rear support bar (E).
4. Repeat for left side.

# 3

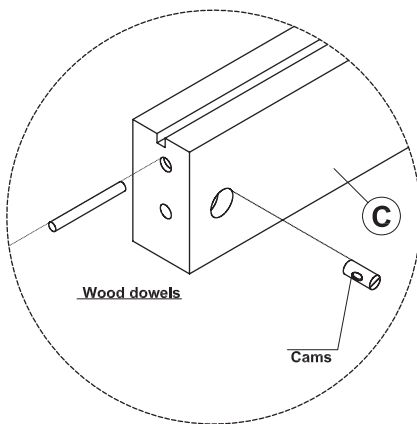
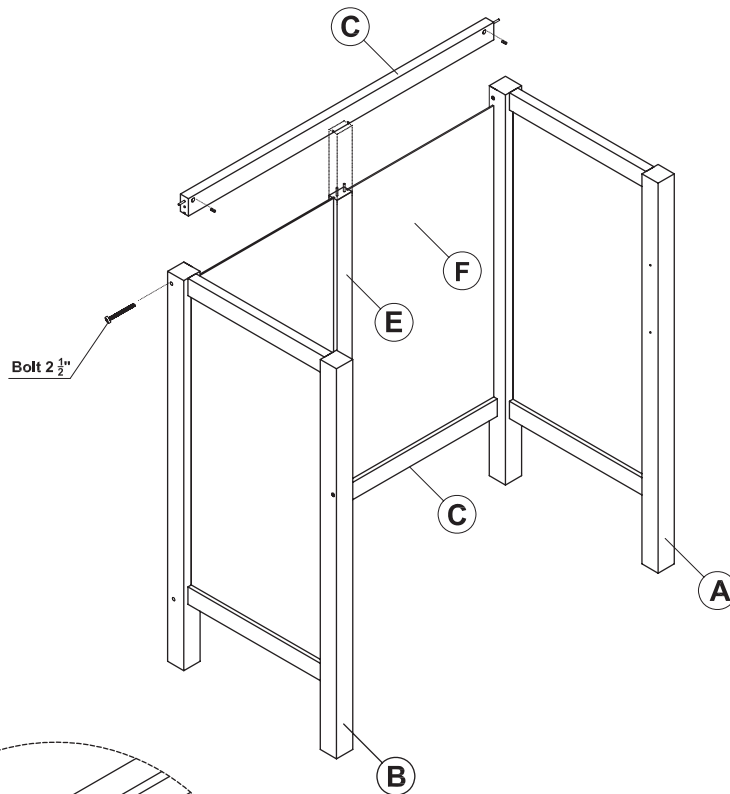

Final image of the Bench Support

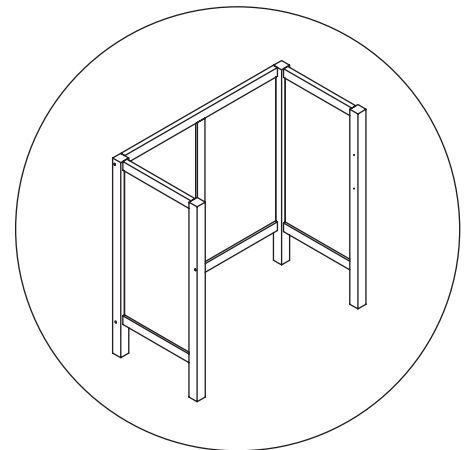

## PARTS IDENTIFICATION

- A Right Side - (1)
- B Left Side - (1)
- C Upper and Lower Crossbars - (*identical*)
- D Rear panel support bar - (1)
- E Back panels - (2 *pieces, identical*)

## STAGE 1- Bench Body

### Asembling

#### **Step 3**

**Attach upper crossbar (C) to sides A and B.**

**1. Insert two cams into crossbar. Note correct position of cam as shown in illustration.**

**2. Insert wood dowels into top hole of crossbar. See illustration**

**3. Fasten both sides to upper crossbar using 2-1/2" bolts. Bolts screw into cams. If alignment is not correct, adjust using screwdriver to rotate the cam. Tighten all bolts, top and bottom, tightly.**

# 4

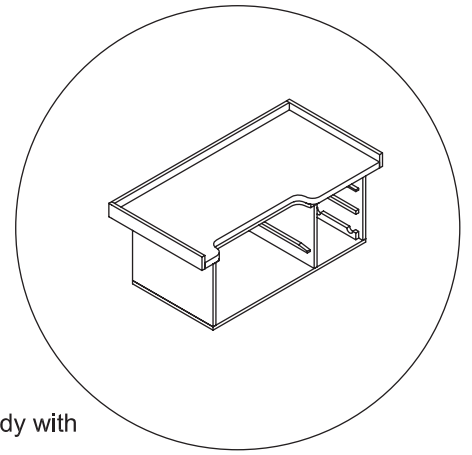
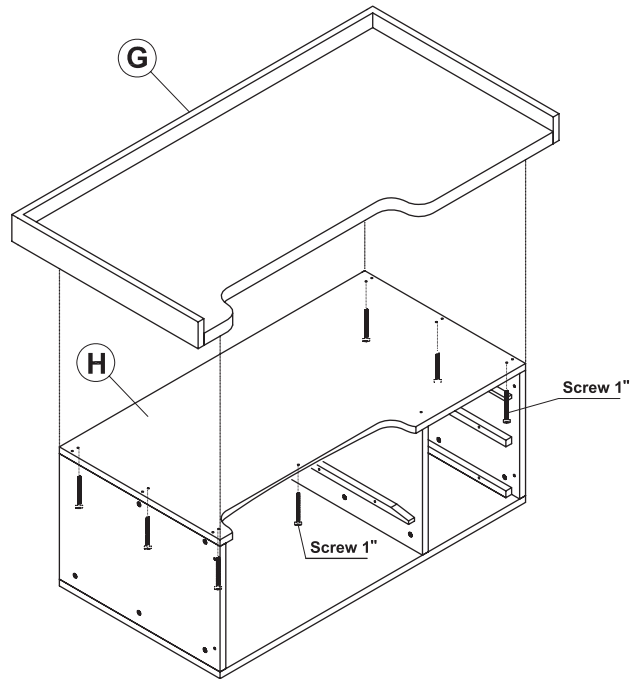

Final image of the Bench Body with  
the Bench Top attached

## **PARTS IDENTIFICATION**

- H Bench body - (1)
- G Bench top - (1)

## **STAGE 2 - Bench Body Assembly**

### **Step 3**

1. Position Bench Top (G) on bench body by lining up recessed portions of both.
2. Attach bench Top (G) to bench body using seven 1" screws.

# 5

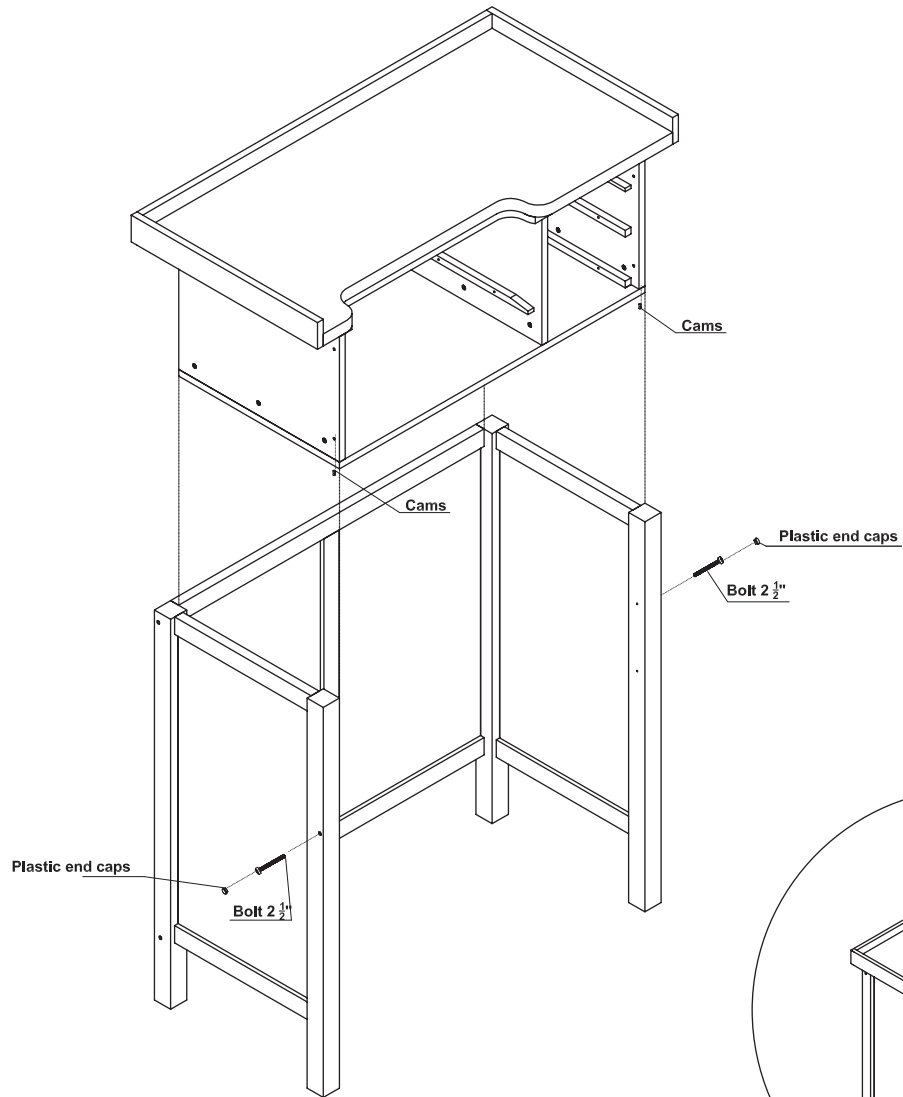

Final image of the Bench Body with the Bench Frame.

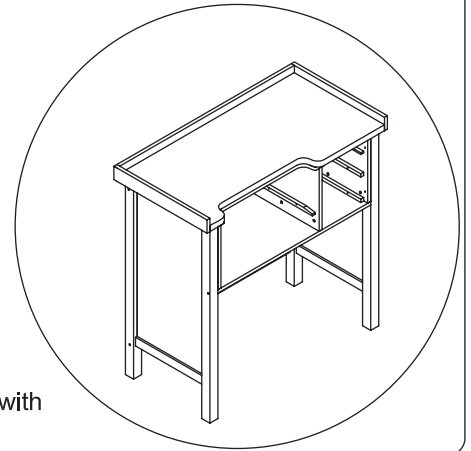

### **STAGE 3 - Attaching Bench Body to Bench Frame.**

1. Fit bench body onto bench frame as shown.
2. Attach with eight 1" screws as shown.
3. Insert cams (2) into bottom of bench body.
4. Secure with 2 1/2" bolts.
5. Place plastic end caps on side panels.

# 6

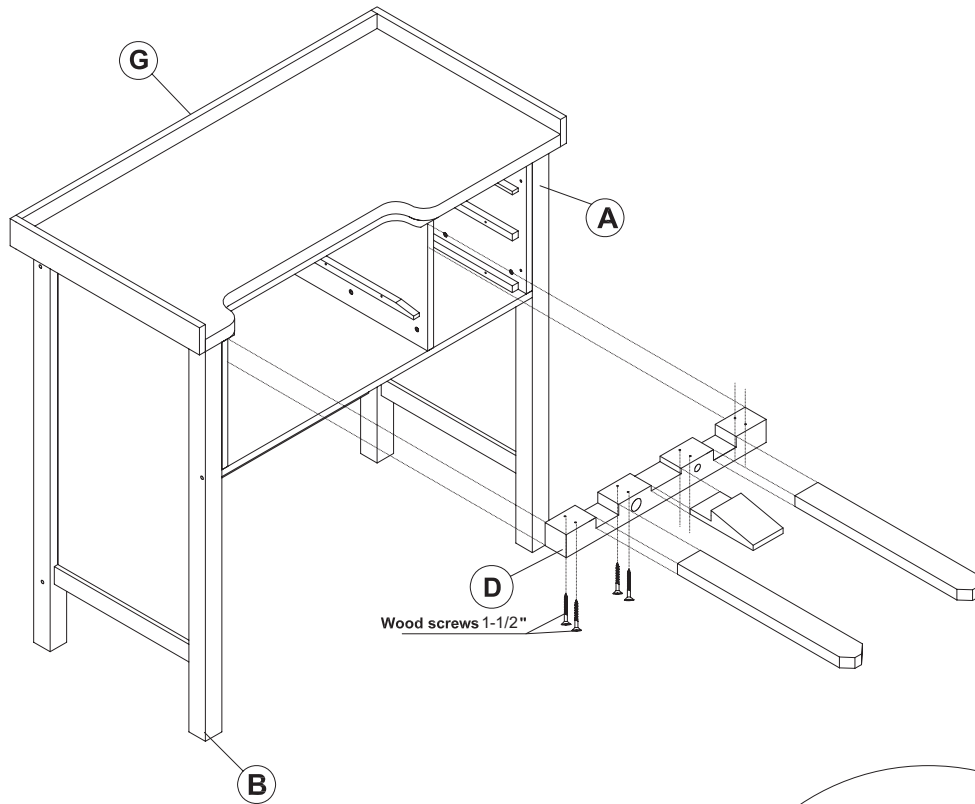

Wood screws 1-1/2"

Final image of the  
drawer assembled

## PARTS IDENTIFICATION

- A Right Side - (1)
- B Left Side - (1)
- G Bench top - (1)
- D Bench pin holer - (1)

## STAGE 5 - Bench Pin Holder Attachment

1. Attach Bench Pin Holder (D) using eight 1-1/2" wood screws. See diagram.



# 7

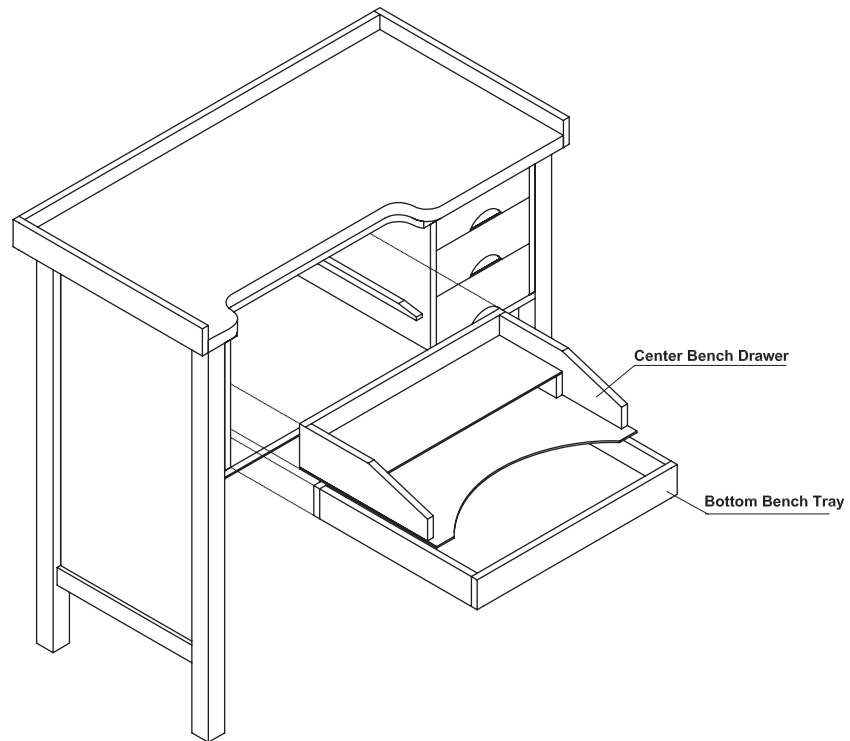

## PARTS IDENTIFICATION

Right Side - (1)

Left Side - (1)

Bench top - (1)

## **STAGE 6**

1. Insert the Center Bench Drawer above the Bottom Bench Tray into the larger desk compartment by placing them onto the drawer tracking.

8



FINAL IMAGES